

QSF-450L-3U FILM PROCESSOR

INSTALLATION SPECIFICATIONS

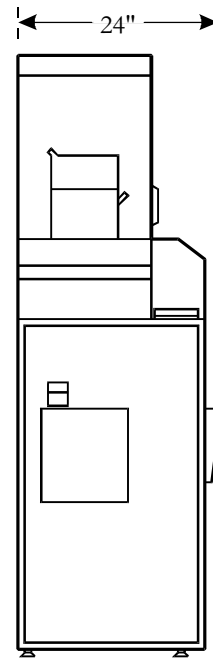
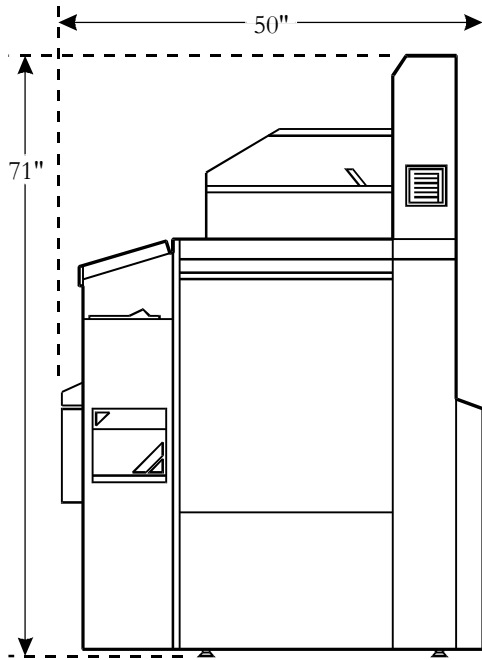

Electrical 120/240 VAC @ 32 Amp. 1 phase
 - 3 Wire plus separate, wire ground

Sensible heat loss 13,120 B.t.u./hour

Operating weight 1072 Lbs.

External dimensions 50" L x 24" W x 71" H

Note: Can be moved through a door or passage as narrow as 24"

Cooling water 1/2 gallon per minute (requires optional kit)

Note: Cooling water not used when room temperature kept at or below 85°F

Minimum Ceiling Height
 For Rack Removal 88"

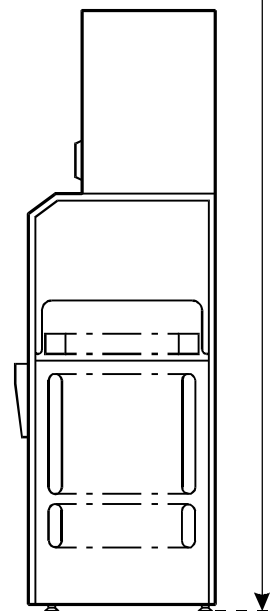
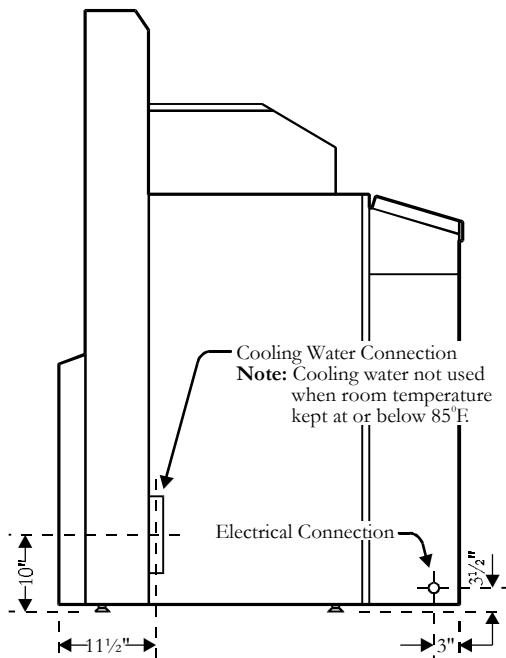

QSF-450L-3U FILM PROCESSOR

PROCESS SPECIFICATIONS

C-41RANP	CD	BL	FIX	STB	DRY
Processing tank capacities (liters)	24.9	9.7	16.9 (2 tanks)	27.1 (3 tanks)	
Operating temperature (Fahrenheit)	100 ±0.25	95 ~ 105	95 ~ 105	95 ~ 105	120 ~ 160
Time per step (seconds)	195	59	103	74	101
Replenisher tank capacities (liters)	12.1	12.1	12.1	12.1	
Waste tank capacities (liters)	15		15		

FILM CAPACITY

Film Size	Rolls/hour
110-24	66
124-24	62
135-24	50
120	62
220	36

FILM PATH

Film Dryer Cabinet

Film Sensors

Film Cutters

Film Cradles

Film Cassette Catch Bin

PROCESSING TANKS

- ① Color Developer
- ② Bleach
- ③ Fix 1
- ④ Fix 2
- ⑤ Stabilizer 1
- ⑥ Stabilizer 2
- ⑦ Stabilizer 3

REPLENISHER TANKS

- ① Color Developer
- ② Bleach
- ③ Fix
- ④ Stabilizer

WASTE RECOVERY TANKS

- ① Silver Bearing
- ② Non-silver Bearing

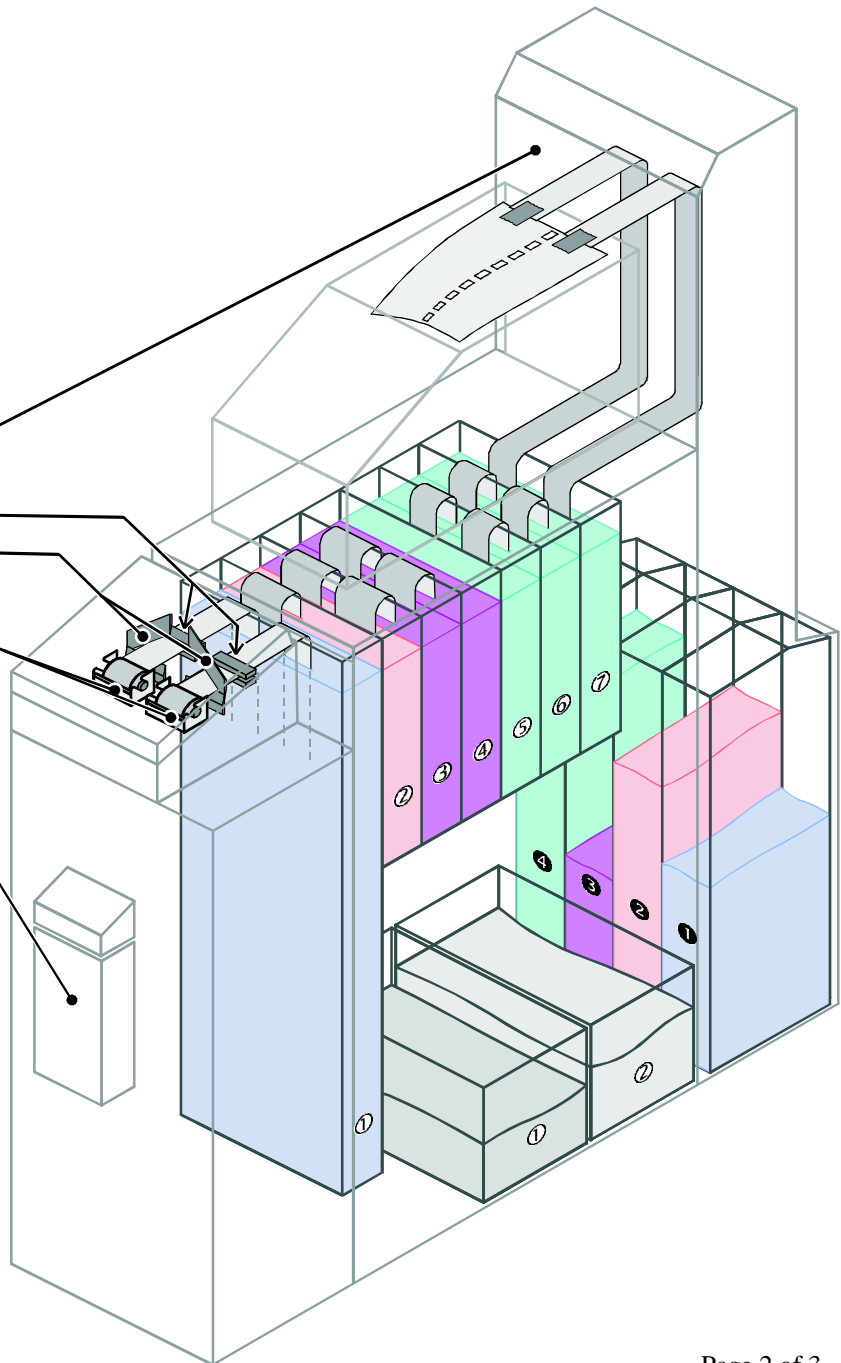

QSF-450L-3U FILM PROCESSOR

Cut out and use with a scaled drawing ($\frac{1}{2}''=1'$) of your floor plan to determine the best location for the equipment.

Note:
Shaded area indicates *minimum* clearance to walls, other equipment, etc. Additional clearance is suggested on the sides shown with the 20" and 38" dimensions and may be required by local codes.

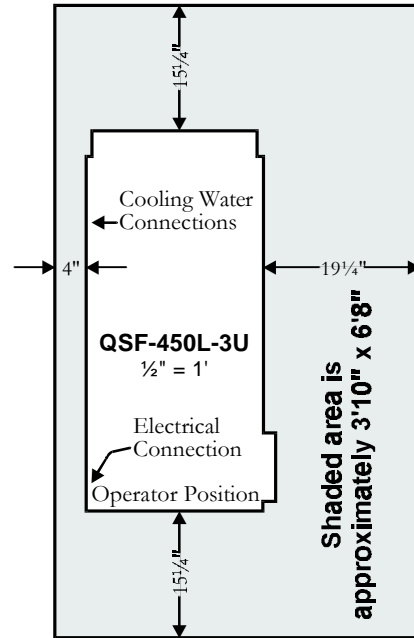

Note: Cooling water not used when room temperature kept at or below 85° F.

Specifications subject to change without notice.

NORITSU AMERICA CORPORATION

Corporate Office: (714) 521-9040
6900 Noritsu Ave., Buena Park, CA 90622-5039

Western Region Office: (714) 521-9040
6950 Noritsu Ave., Buena Park, CA 90622-5039

Eastern Regional Office: (201) 808-9898
336 Route 46 East, Fairfield, NJ 07004-2429

Midwest Regional Office: (708) 888-8000
755 Tollgate Road, Elgin, IL 60123-9301

Southern Regional Office: (214) 631-2400
2989 North Stemmons Fwy., Dallas, TX 75247-6193

U.S. Government Sales Office: (703) 821-0007
1420 Spring Hill Rd., Suite 600, McLean, VA 22102-3006

Noritsu Canada Ltd: (905) 567-8982
2680 Argenta Road, Mississauga, Ontario L5N-5V4