

# QSF-430L-3(U) FILM PROCESSOR

## INSTALLATION SPECIFICATIONS

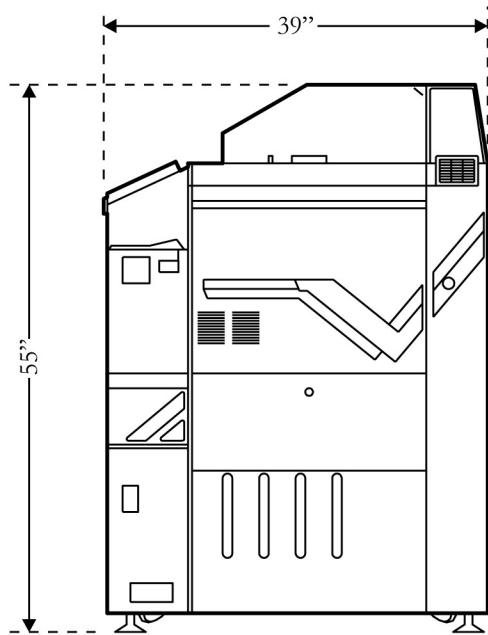

RIGHT SIDE

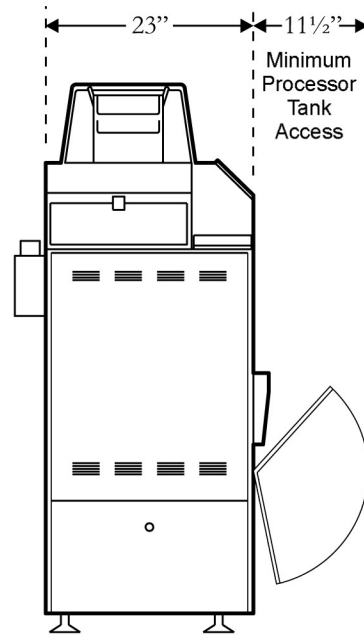

FRONT

Electrical . . . . .120/240 VAC Single phase 19 Amp.

**Note:** Requires 3 wire feed plus separate ground wire feed

Sensible heat loss . . . . .7,790 B.t.u./hour

Operating weight . . . . .735 Lbs.

External dimensions . . . . .39" L x 23" W x 55" H

**Note:** Requires a minimum opening of 24" to move through a door or passage

Cooling water . . . . . 1/2 gallon per minute

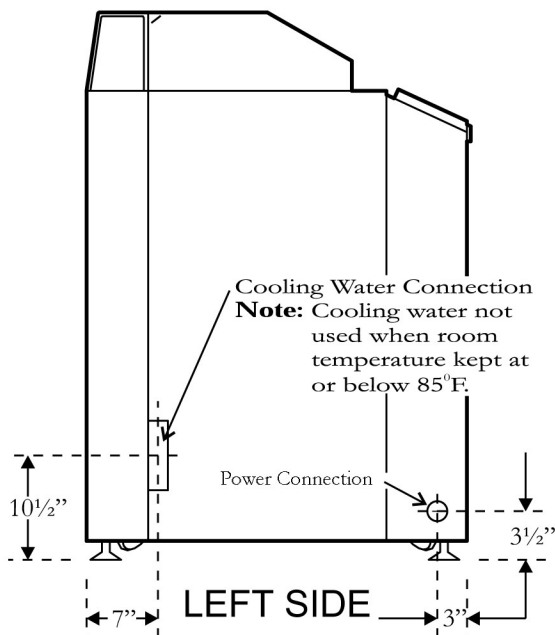

LEFT SIDE

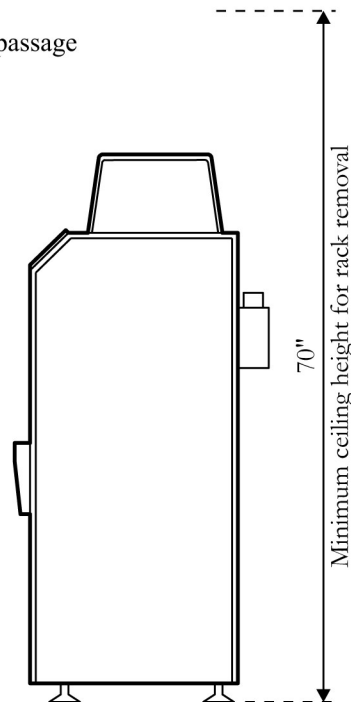

BACK

# QSF-430L-3(U) FILM PROCESSOR

## FILM CAPACITY PER HOUR (C-41 RA4NP)

Film size	Rolls
110-24	34
126-24	32
135-24	26
120	32
220	18

## FILM PATH

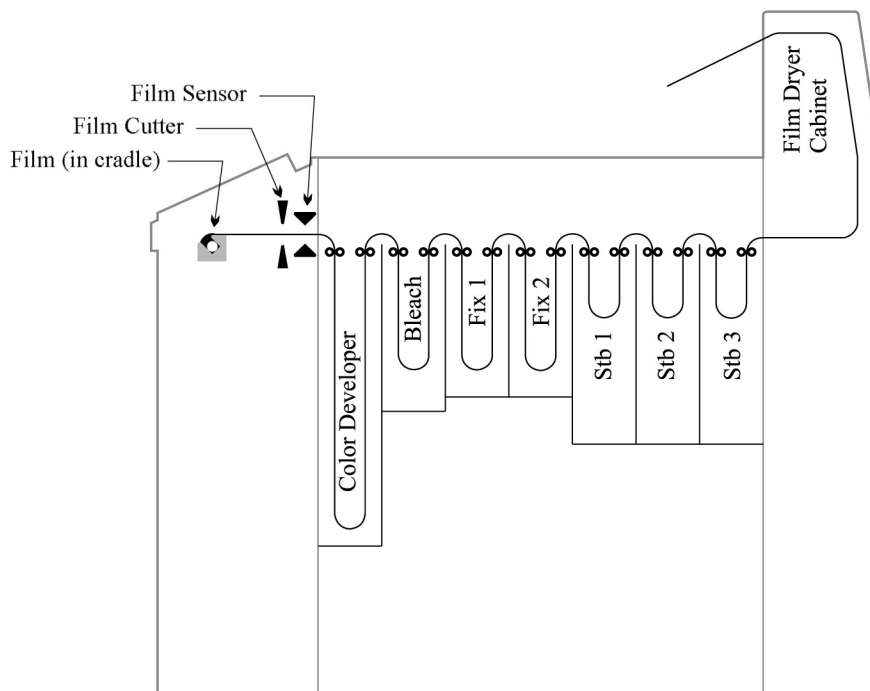

## PROCESS SPECIFICATIONS

C-41RANP	CD	BL	FIX	STB	DRY
Processing tank capacities (liters)	11.5	5.0	8.9 (2 tanks)	22.9 (3 tanks)	
Operating temperature (Fahrenheit)	100 ±0.25	95~105	95~105	95~105	122 ~ 158
Time per step (seconds)	195	68	135	115	132
Replenisher tank capacities (liters)	12	12	12	12	
Waste tank capacities (liters)	8.5		8.5		

# QSF-430L-3(U) FILM PROCESSOR

Cut out and use with a scaled drawing ( $\frac{1}{2}'' = 1'$ ) of your floor plan to determine the best location for the equipment.

Note:

Shaded area indicates *minimum* clearance to walls, other equipment, etc. Additional clearance is suggested on all sides (except side to the left of the operator's position) and may be required by local codes.

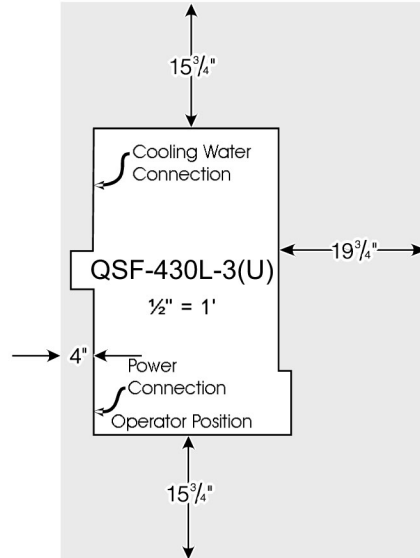

**Note:** Cooling water not used when room temperature kept at or below 85°F.

---

## NORITSU AMERICA CORPORATION

**Corporate Office:** (714) 521-9040  
6900 Noritsu Ave., Buena Park, CA 90622-5039

**Western Regional Office:** (714) 521-9040  
6950 Ave., Buena Park, CA 90622-5039

**Eastern Regional Office:** (201) 808-9898  
336 Route 46 East, Fairfield, NJ 07004-2429

**Midwest Regional Office:** (708) 888-8000  
755 Tollgate Road, Elgin, IL 60123-9301

**Southern Regional Office:** (214) 631-2400  
2989 North Stemmons Fwy., Dallas, TX 75247-6193

**U.S. Government Sales Office:** (703) 821-0007  
1420 Spring Hill Rd., Suite 600, McLean, VA 22102-3006

**Noritsu Canada Ltd:** (905) 567-8982