

SPECIFICATIONS

Type:	Floor-type, daylight operation.
Transport system:	Leader and timing belt.
Processing speed:	FP362B/362B AL: 467 mm/min. FP562B/562B AL: 672 mm/min. FP922 AL: 1,170 mm/min.
Processing time:	FP362B/362B AL: 10 min. 32 sec. (dry to dry). FP562B/562B AL: 8 min. 24 sec. (dry to dry). FP922 AL: 8 min. 13 sec. (dry to dry).
Films:	FP362B/362B AL, FP562B/562B AL: 135, 126, 110, 120, 220, IX240. FP922 AL: 135, 126, 110, IX240.
Processing chemicals:	CN-16L.
Processing capacity:	FP362B/362B AL: 36 rolls/hr. (135/24 exp., 2-strip processing). 48 rolls/hr. (120, 2-strip processing). 38 rolls/hr. (IX240/25 exp., 2-strip processing). FP562B/562B AL: 56 rolls/hr. (135/24 exp., 2-strip processing). 70 rolls/hr. (120, 2-strip processing). 56 rolls/hr. (IX240/25 exp., 2-strip processing). FP922 AL: 92 rolls/hr. (135/24 exp., 2-strip processing). 92 rolls/hr. (IX240/25 exp., 2-strip processing).
Tank capacity:	N1 N2 N3-1 N3-2 NS N4-1 N4-2 FP362B/362B AL: 11.5ℓ 5.0ℓ 5.0ℓ 5.0ℓ 3.0ℓ 3.0ℓ 3.0ℓ FP562B/562B AL: 17.2ℓ 5.0ℓ 5.0ℓ 5.0ℓ 3.5ℓ 3.0ℓ 3.0ℓ FP922 AL: 31.2ℓ 8.9ℓ 7.7ℓ 7.7ℓ 6.0ℓ 4.5ℓ 4.7ℓ
Replenishment tanks:	N1 N2 N3 NS N4 FP362B/362B AL: 11.5ℓ 5.0ℓ 5.0ℓ 11.5ℓ 11.5ℓ FP562B/562B AL: 11.5ℓ 6.5ℓ 6.5ℓ 13.5ℓ 11.5ℓ FP922 AL: 13.5ℓ 11.5ℓ 11.5ℓ 13.5ℓ 11.5ℓ (with simplified mixing device and solution level detector).
Waste solution tanks:	FP362B/362B AL 11.0ℓ×2 FP562B/562B AL 17.6ℓ×2 FP922 AL 20.0ℓ×2 (with solution level detector).
Weekly timer:	Standard.
Film collection:	Stored on hanger by leader suspension.
Drying:	Auto switchover of drying temperature by detection of film size.
Power consumption:	FP362B/362B AL: AC 200~240 V, single phase (50/60 Hz), 3.2~3.8 kVA. FP562B/562B AL: AC 200~240 V, single phase (50/60 Hz), 4.2~4.8 kVA. FP922 AL: UL/CSA-type: AC 200~240 V, single phase (50/60 Hz), 4.8~5.5 kVA. GS-type: 3 phase, 4 wires, AC 380/400/415 V, 4.8~5.5 kVA.
Dimensions:	FP362B 690(W)×1,223(D)×1,401(H) mm. FP362B AL 690(W)×1,435(D)×1,604(H) mm. FP562B 690(W)×1,299(D)×1,401(H) mm. FP562B AL 690(W)×1,511(D)×1,604(H) mm. FP922 AL 690(W)×1,587(D)×1,605(H) mm.
Weight:	FP362B 180 kg (when in operation: 290 kg). FP362B AL 182 kg (when in operation: 292 kg). FP562B 204 kg (when in operation: 300 kg). FP562B AL 206 kg (when in operation: 302 kg). FP922 AL 230 kg (when in operation: 390 kg).

•Specifications are subject to change without notice.

Dimensions

Unit: mm

FP362B/FP562B

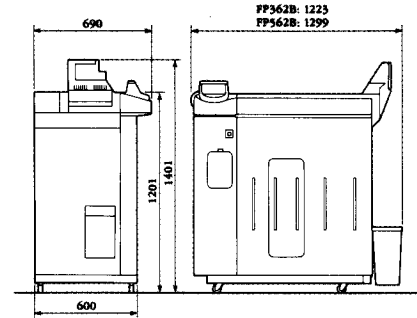

FP362B AL/FP562B AL/FP922 AL

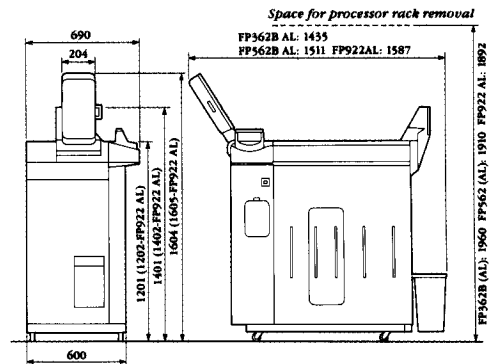

 **FUJIFILM**

FUJI PHOTO FILM CO., LTD.

26-30, NISHIAZABU 2-CHOME, MINATO-KU, TOKYO 106, JAPAN